

TOPBALL® PRODUCTS

SLIDE GUIDE

BALL SPLINE
ROTARY BALL SPLINE

TOPBALL® PRODUCTS

SLIDE BUSH

SLIDE UNIT

STROKE BUSH
SLIDE ROTARY BUSH

SLIDE SHAFT

SLIDE WAY
SLIDE TABLE
GONIO WAY

ACTUATOR

SLIDE SCREW

ISOTECH, inc.

777 Schwab Road, Suite T, Hatfield, PA 19440
Toll Free: 800-314-3332 Fax: 215-631-9148

NB TOPBALL® PRODUCTS

NB now offers a new standard in linear motion with TOPBALL. The TOPBALL slide bush is a high performance bushing with three times the load capacity, capable of providing up to 27 times normal travel life of a conventional slide bushing.

TOPBALL is available in a variety of configurations to fit various service conditions. NB's self-aligning TOPBALL can be designed into many different applications such as factory automated equipment, machine tools, industrial machines, electrical equipment, optical and measuring instruments.

In the early stages of NB's development of TOPBALL, careful thought and consideration was given to such factors as quality, cost, performance and interchangeability. The results of these efforts are reflected in the TOPBALL features.

TOPBALL FEATURES

1. Increased Load Capacity:

NB's uniquely designed ground load plate provides circular arch contact to the ball element resulting in a greater dispersion of the load, enabling TOPBALL to provide three times the load capacity of conventional slide bushings.

2. Longer Travel Life:

Dispersed stress on the load plate provides TOPBALL up to 27 times the travel life of conventional slide bushings.

3. Self Aligning Capability:

Load plates are thinner at the ends to provide a pivot point at the center of the plate. The center acts as a fulcrum to compensate for any slight misalignment between the shaft and the housing bore that might be caused by inaccurate machining, mounting errors or shaft deflection.

Figure C-1 Illustrating circular arch design and ground surface raceway

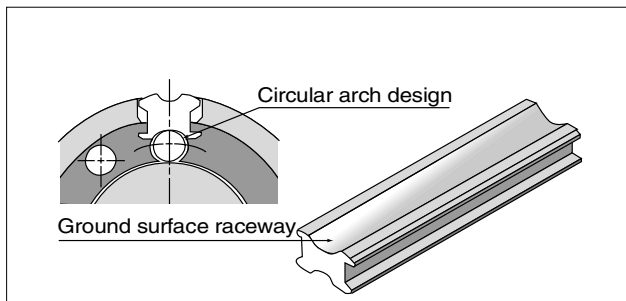

4. Floating Integral Wiper Seal:

NB's unique floating seal design allows for self-alignment while maintaining equal and constant contact to the shaft. Seals do not add to the overall length of the bushing allowing for more compact designs.

5. Clearance Adjustable:

TOPBALL load plates are designed to "float" in the outer sleeve which allows for clearance between the ball elements and shaft to best suit application requirements.

6. Cost Effectiveness:

TOPBALL's higher load capability and longer travel life enables the use of smaller components such as bushings, housings and shafts, reducing material cost and the overall cost of the system. Longer travel life also extends replacement periods and reduce maintenance cost.

Figure C-2 Illustrating floating seal and self-aligning feature

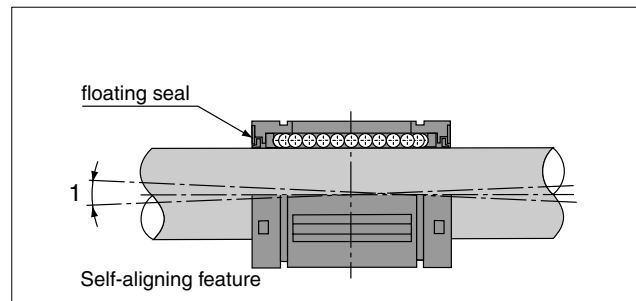

TYPES

		Metric series		Inch series	
TOPBALL	closed type	TK  P.C-8	TW  P.C-10		
	open type	TK-OP  P.C-8	TW-OP  P.C-10		
TOPBALL unit	closed type	TKA  P.C-12	TKA-W  P.C-13	TWA  P.C-18	TWA-W  P.C-19
	adjustable type	/		TWJ  P.C-20	TWJ-W  P.C-21
	open type	TKE  P.C-14	TKE-W  P.C-15	/	
	adjustable-open type	TKD  P.C-16	TKD-W  P.C-17	TWD  P.C-22	TWD-W  P.C-23

RATED LIFE

The life of a slide bush can be easily calculated with the load rating of the bush, shaft hardness and applicable load. However, in many cases, slide bushing failure may be caused by improper design of peripherals, including the shaft and housing, inappropriate mounting or improper operation. Serious consideration of these peripheral factors, in addition to load rating, are highly recommended when designing a slide bush application.

Basic Dynamic Load Rating and Life Expectancy:

The basic dynamic load rating is the load which allows a rating life of 50km, without changing its magnitude and direction. The rating life can be obtained from the following equation.

$$L = \left(\frac{C}{P}\right)^3 \cdot 50 \quad \text{Equation (1)}$$

L : travel life (km)
C : basic dynamic load rating (N)
P : load (N)

Figure C-3 shows the relationship between rating life (L) and load ratio (C/P). In the practical use of a bushing, other factors that affect the life, such as shaft hardness and load condition should be considered. The equation for calculating bushing life considering these additional factors is:

$$L = \left(\frac{f_H}{f_w} \cdot \frac{C}{P}\right)^3 \cdot 50 \quad \text{Equation (2)}$$

f_H : hardness coefficient (See Figure C-4)
f_w : load coefficient (See Table C-1)

Life time can be calculated by obtaining the travelling distance per unit of time as follows:

$$L_h = \frac{L \cdot 10^3}{2 \cdot L_s \cdot N_1 \cdot 60} \quad \text{Equation (3)}$$

L_h : life time (hr)
L_s : stroke length (m)
N₁ : stroke frequency per min. (cpm)
L : travel life (km)

Figure C-3: Slide Bush Life

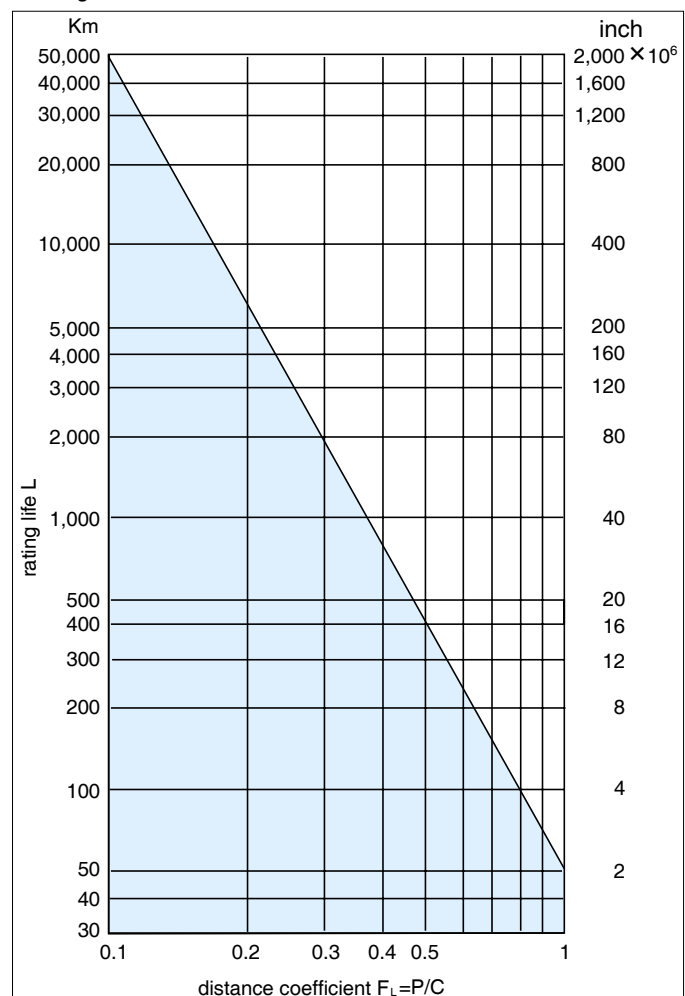

Load coefficient (fw):

When calculating the bush load, it is necessary to accurately obtain weight, inertial force based on speed, moment load and each transition as time passes. However, it is difficult to calculate those values accurately because reciprocating motion involves the repetition of starts and stops as well as vibration and impact. A more practical approach is to obtain the load coefficient by taking the actual operating conditions into account.

Table C-1: Load Coefficient

OPERATING CONDITIONS	fw
operation at low speed (15m/min. or less) without impulsive shock from outside	1.0-1.5
operation at intermediate speed (60m/min.or less) without impulsive shock	1.5-2.0
operation at high speed (over 60m/min.) with impulsive shock	2.0-3.5

Hardness Coefficient (fH):

The shaft must be hardened to over 58HRC when a slide bush is used. If not properly hardened, permissible load is lowered and the life of the bushing will be shortened.

Figure C-4: Hardness coefficient

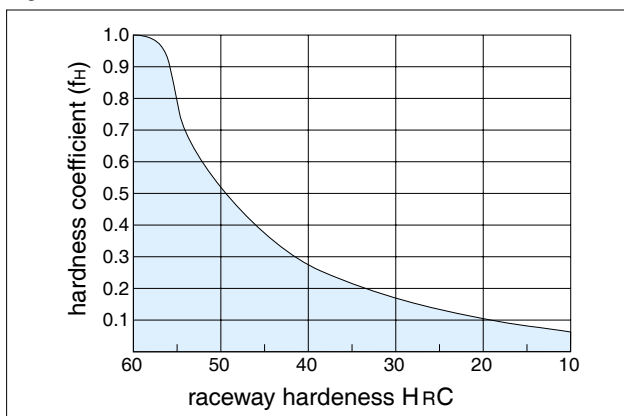

Examples of Calculations:

(1) Life expectancy when NB's TOPBALL TK 25 is used under the following conditions:

Load per bush: 668N
 Stroke length: 0.2m
 Rate of cycles/min: 35
 Shaft hardness: 60HRC

From the basic dynamic load of TK25 is 3780N, hardness coefficient(fH) is 1.0, and the operating speed can be calculated as 0.014km/min. Therefore, the load coefficient(fw) is considered as 1.0.

Using Equation (1) (Page C-4)

$$L = \left(\frac{3780}{668} \right)^3 \cdot 50 = 9,060 \text{ km}$$

Using Equation (3) (Page C-4)

$$L_h = \frac{9,060 \cdot 10^3}{2 \cdot 0.2 \cdot 35 \cdot 60} = 10,800 \text{ hours}$$

(2) Selection of size for the application

Expected life: 15,000 hours
 Number of bushings in the carriage: 4
 Gross weight on the carriage: 668N
 Stroke length: 0.0009km
 Traveling speed: 0.03km/min.
 Shaft hardness: 60-64HRC

The life expected in traveling distance is:

$$L = 15,000 \cdot 0.03 \cdot 60 = 27,000 \text{ km} (2.7 \times 10^4)$$

From Equation (2)

$$C = \sqrt[3]{\frac{27000}{50} \cdot \left(\frac{fw}{fH} \right)} \cdot P = 2,040 \text{ N}$$

Note that: fH=1.0, fw=1.5, P=668/4=167N

As a result, the TOPBALL that is able to handle this load is: TK20.

Basic Static Load Rating:

If a slide bush is loaded when it is in a stationary condition or working at a low speed, a permanent elastic deformation is formed on the rolling element. The deformation prevents smooth movement of the bushing. To eliminate this possibility, the basic static load rating must not be exceeded.

Relation Between Ball Circuits and Load Rating:

The load rating of a slide bush varies according to the loaded position on the circumference. The value in the dimensional table indicates the lowest load rating with the load placed on top of one ball circuit. If the slide bush is used with two ball circuits loaded uniformly, the value will be greater. Table C-2 shows the load ratio for the number of ball circuits in each case.

Clearance and Fit:

An appropriate clearance between the slide bush and shaft is required in TOPBALL operation. Inadequate clearance may cause early failure and/or poor, rough movement. Proper clearance is determined by shaft diameter and housing bore. Table C-3 and C-4 shows **NB's** recommended tolerances of the shaft and housing bore in order to maintain the appropriate clearance.

Table C-2: Optional Load Positions

NUMBER OF ROWS	4	5	6
Co (LOAD RATING SPECIFIED ON THE TABLE)			
Comax (MAXIMUM LOAD RATING)			
LOAD RATIO Comax/Co	1,414	1,463	1,280

Table C-3: Recommended Tolerance for Shaft Dia. and Housing Bore

part number	shaft dia.		housing bore	
	dr mm	tol. (h6) μ m	D mm	tol. (H7) μ m
TK10	10	0	19	+21
TK12	12		22	
TK16	16	-11	26	0
TK20	20	0	32	+25
TK25	25		40	
TK30	30	-13	47	0
TK40	40	0/-16	62	+30/0

Table C-4: Recommended Tolerance for Shaft Dia. and Housing Bore

size	shaft dia.		housing bore.	
	dr inch	tol. (g6) inch	D inch	tol. (H7) inch
TW 3	.1875	-.0002 -.0006	.3750	+.0005 0
TW 4	.2500		.5000	+.0007 0
TW 6	.3750	-.0002 -.0007	.6250	+.0008 0
TW 8	.5000		.8750	
TW10	.6250	-.0003 -.0008	1.1250	+.0010 0
TW12	.7500		1.2500	
TW16	1.0000	-.0004 -.0010	1.5625	+.0012 0
TW20	1.2500		2.0000	
TW24	1.5000	-.0004 -.0012	2.3750	0
TW32	2.0000		3.0000	

Shaft and Housing:

To optimize **NB** TOPBALL performance, high precision shafts and housings are required.

1. Shaft: Dimensional tolerance, surface finish and hardness greatly affect the traveling performance of the TOPBALL. The shaft must be manufactured to the following tolerances.

- A. A surface finish of 0.4Ra or less.
- B. Hardness of 60 HRC or more. Hardness less than 60 HRC decreases the life considerably and reduces the permissible load.
- C. The correct tolerance of the shaft diameter is recommended on Table C-3 and C-4 (Page C-6).

The **NB** Slide Shaft is an ideal component manufactured to these specifications. For details, please refer to Page G-2 to G-21.

2. Housing: There are a wide range of designs and manufacturing techniques for mounted housings. **NB** pre-engineered slide units are also available. For proper fit refer to Table C-3 and C-4 (Page C-6).

Mounting:

TOPBALL is designed to be press fitted into the housing bore. When inserting bushing, however, don't apply excess force nor shock load which may cause permanent damage.

Examples of Mounting

Figures C-5 to C-8 illustrate mounting methods as examples.

Figure C-5 Use of holding plates

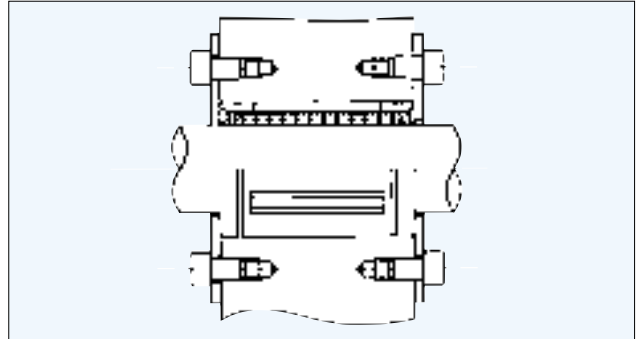

Figure C-6 Adjustable type housing

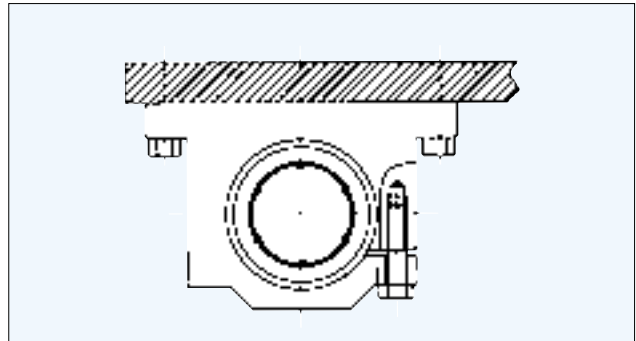

Figure C-7 Use of external retaining rings

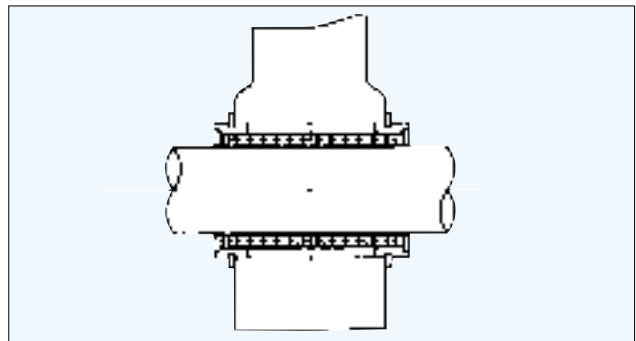

Figure C-8 Open type housing

