

**NEW PRODUCT**

# ROTARY BALL SPLINE

## SPR type

**“Linear Motion” + “Rotation”**

11 sizes are now available as standard product offering,  
from the miniature size (6mm) up to the large size (60mm) .



Certificate No.958188

**ISOTECH, inc.**

777 Schwab Road, Suite T, Hatfield, PA 19440  
Toll Free: 800-314-3332 Fax: 215-631-9148

# ROTARY BALL SPLINE

The NB rotary ball spline can be used for both rotational motion and linear motion. It can be used in scalar robots, the vertical shaft of assembly equipment, and tool changers and loaders.

## STRUCTURE AND ADVANTAGES

The NB rotary ball spline consists of a spline shaft and a nut. The nut has a spline portion and a rotating portion.

### Reduced Number of Parts:

Because of the single-body construction consisting of the rotating portion which is equipped with cross roller elements and the spline portion, the number of parts is reduced and the cumulative installation error is reduced.

### Compact and Light:

The cross roller is directly attached to the ball spline's external cylinder, resulting in a compact and light design.

### Substantial Reduction in Installation Cost:

The use of cross roller elements keeps the housing thickness to a minimum, making the ball spline light and easy to install.

### High Rigidity:

The cross roller elements and 4-row ball circuit structure provides high rigidity in spite of the compact design.

### High Accuracy:

The cross roller elements ensure accurate positioning in the rotational direction.

Figure 1 Structure of NB Rotary Ball Spline

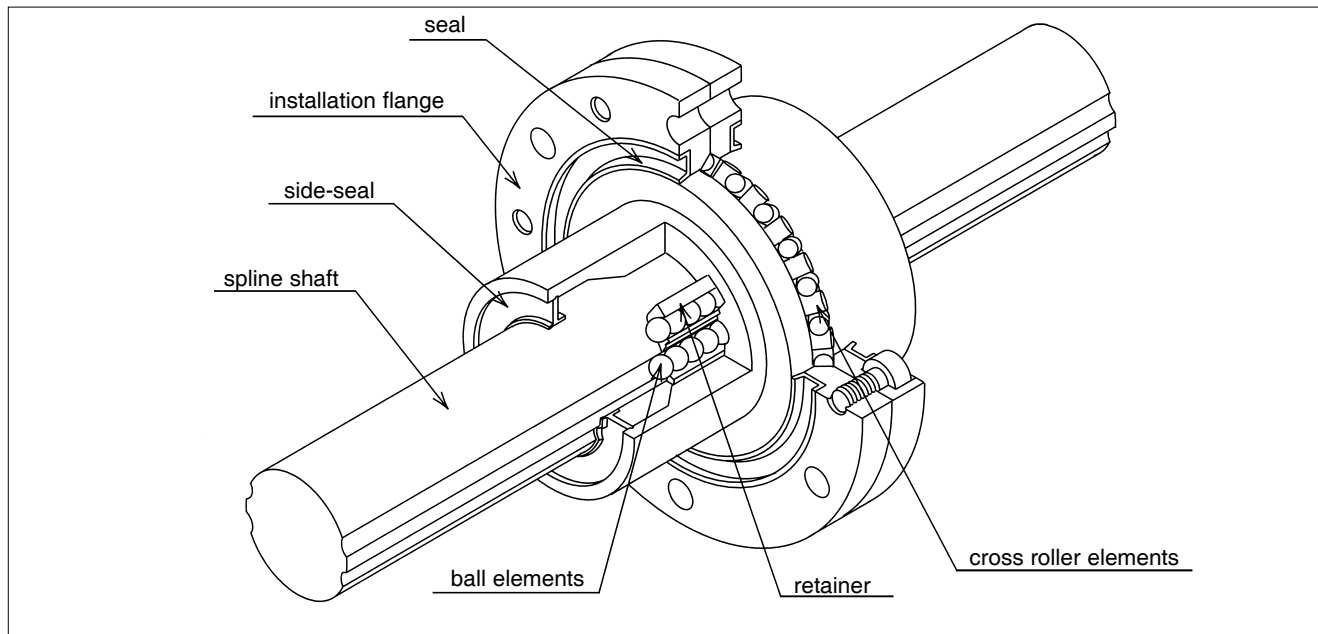

## ACCURACY

The accuracy of the NB rotary ball spline is measured as shown in figure 2.

Figure 2 Accuracy Measurement Points

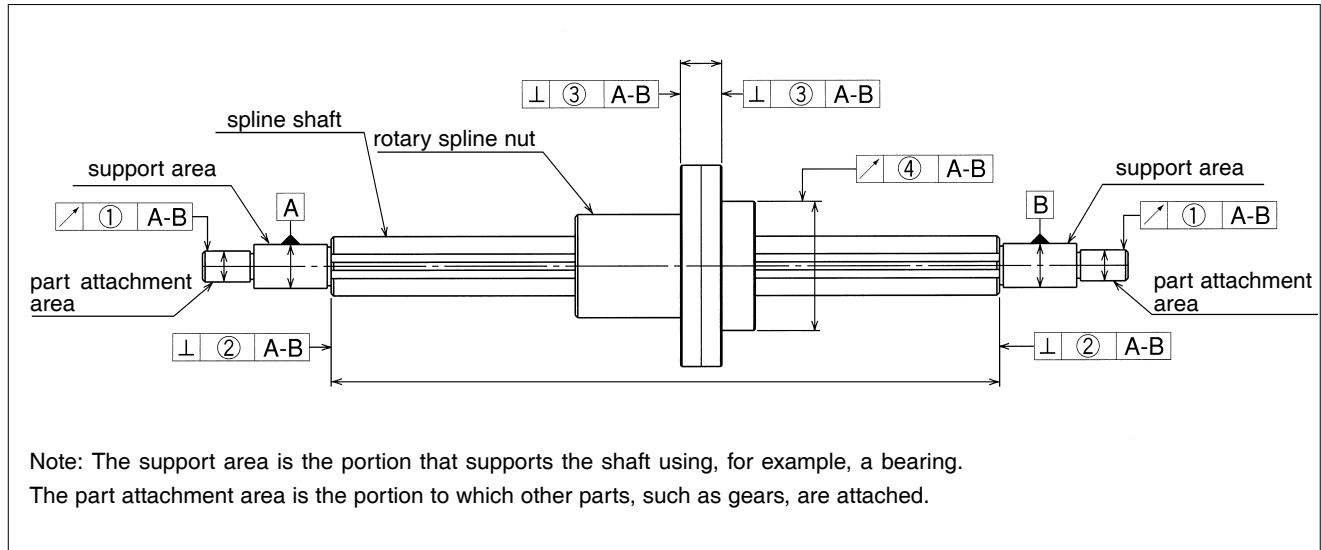

Table 1 Tolerance of Spline Shaft Groove Torsion (Max)

accuracy grade	high
tolerance	13 $\mu\text{m}/100\text{mm}$

The groove torsion is indicated for 100mm, arbitrarily set as the effective length of the spline section. When the movement rate is under 100mm or exceeds 100mm, the value shown in the table 1 increases or decreases proportionally to the movement rate.

Table 2 Tolerance of Parts Relative to Spline Support Area unit/ $\mu\text{m}$

part number	①radial run out of part attachment area	②perpendicularity of the end of the spline shaft section	③perpendicularity of the flange
SPR 6	14	9	14
SPR 8			
SPR10			
SPR13	19	11	18
SPR16			
SPR20			
SPR25	22	13	21
SPR30			
SPR40			
SPR50	25	16	25
SPR60			
	29	19	29

Table 3 ④Radial Run Out of Outer Surface of Rotary Spline Nut Relative to Spline Support Area

unit/ $\mu\text{m}$

spline shaft total length		part number					
greater than	or less	SPR6,8	SPR10	SPR13,16	SPR20,25,30	SPR40,50	SPR60
	200	46	36	34	32	32	30
200	315	89	54	45	39	36	34
315	400	126	68	53	44	39	36
400	500	163*	82	62	50	43	38
500	630	—	102	75	57	47	41
630	800	—	—	—	68	54	45
800	1,000	—	—	—	83	63	51
1,000	1,250	—	—	—	102	76	59
1,250	1,600	—	—	—	130	93	70
1,600	2,000	—	—	—	171	118	86

\*Contact NB for spline shafts exceeding 2000mm.  
SPR6 spline shaft max. length : 400mm

## PRE-LOAD AND CLEARANCE IN ROTATIONAL DIRECTION

The amount of clearance and pre-load for the spline portion and the cross-roller portion are expressed in terms of the clearance in the rotational direction and the clearance in the radial direction, respectively. Three levels of pre-load are available: standard, light (T1), and medium (T2).

Table 4 Pre-Load and Clearance in Rotational Direction unit/ $\mu\text{m}$

	part number	standard	light (T1)	medium (T2)
linear motion	SPR 6	-2~+1	-6~-2	-
	SPR 8			
	SPR10	-3~+1	-8~-3	-13~-8
	SPR13			
	SPR16			
	SPR20	-4~+2	-12~-4	-20~-12
	SPR25			
	SPR30			
	SPR40			
	SPR50	-6~+3	-18~-6	-30~-18
SPR60				
rotational motion	SPR 6 ~ SPR60	$\pm 5$		

Table 5 Operating Condition and Pre-Load

pre-load	symbol	operating condition
standard	blank	Minute vibration is applied. A precise motion is required. Moment is applied in a given direction.
light	T1	Light vibration is applied. Light torsional load is applied. Cyclic torque is applied.
medium	T2	Shock/vibration is applied. Over-hang load is applied. Torsional load is applied.

## SPECIAL REQUIREMENTS

NB will fabricate special shaft ends, spline nuts, spline shafts, surface finish etc. to meet customer requirements. Contact NB for details.

Figure 3 Examples of Shaft End Machining

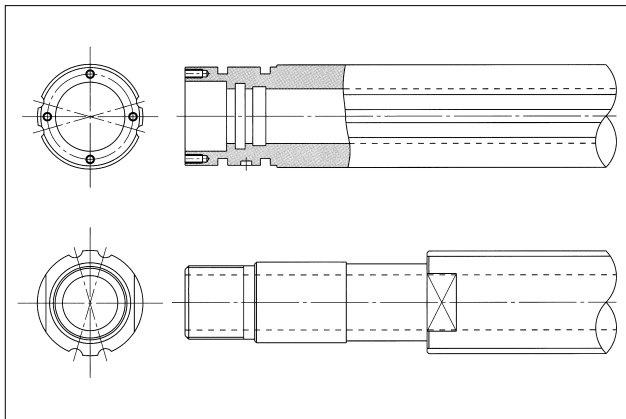
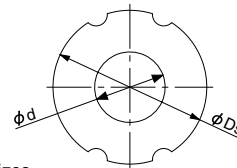

Table 6 recommended hollow shaft

part number	outer dia. mm	inner dia. mm	modulus of section $\text{mm}^3$	geometrical moment of inertia $\text{mm}^4$
SPR 6	6	2	19.4	58
SPR 8	8	3	46.5	186
SPR10	10	4	89.6	448
SPR13	13	6	193	1,260
SPR16	16	8	348	2,780



Contact NB for other sizes.

## OPERATING ENVIRONMENT

Certain operating environments may prevent the full functionality of the rotary ball spline from being achieved. The operating environment should be taken into consideration when designing the system.

### Operating Temperature:

Resin retainers are used in the rotary ball spline, so the operating temperature should never exceed 80°C.

### Dust Prevention:

The invasion of foreign particles and dust may affect the motion characteristics of the rotary ball spline and shorten the travel life. Seals will perform well under normal operating conditions, but may not completely prevent the entry of dust in a hostile environment. When used in such environments, a dust prevention mechanism such as bellows or a cover should be used to protect the rotary ball spline.

## MOUNTING OF ROTARY BALL SPLINE

The flange attachment bolts have been pre-adjusted for smooth rotary movement and should never be loosened. Shock loading to the flange assembly should be avoided as this can degrade the accuracy of movement and deteriorate the overall performance.

### Mounting:

When the flange is to be used with a faucet joint (as shown in Figure 4) the housing bore should be machined to a tolerance of H7 and to a minimum depth of 60% of the flange thickness. If only a light load is applied to the SPR in operation, the flange can be used without a pilot end.

When the mounting bolts are applied, they should be tightened diagonally in steps with progressively more torque at each step. A torque wrench should be used to achieve uniform torque. The recommended torque values for medium-hardness steel bolts are listed in Table 7.

### Insertion of Spline Shaft:

When inserting the rotary ball spline shaft into the spline nut, ensure that the ball elements do not drop out. This is accomplished by aligning the raceway grooves of the shaft with the rows of ball elements in the nut. Then simply insert the spline shaft through the spline nut.

## LUBRICATION

Since NB rotary ball splines are equipped with seals at both the spline portion and the rotational portion, the lubricant is retained for an extended period of time. Lithium soap grease is applied prior to shipment, so they can be used immediately without having to apply lubricant. Lubricant should be added periodically and depending on the operating conditions.

A grease fitting can be installed as an optional feature for sizes 20 to 60, however, an oil lubricant should be used for high-speed applications. Contact NB for further details.

Figure 4 Flange mounting Method

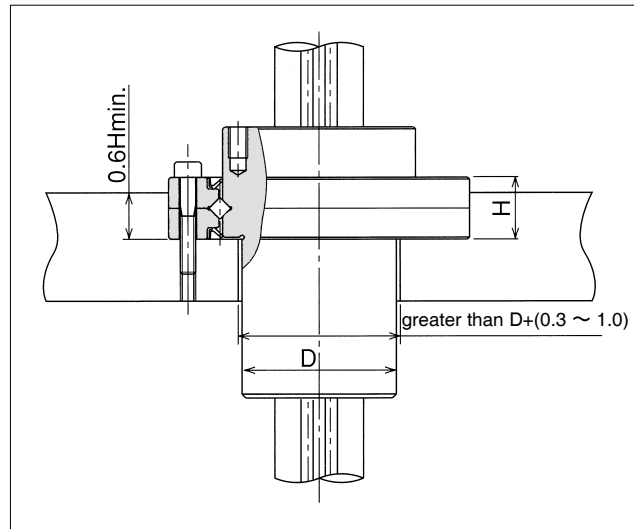
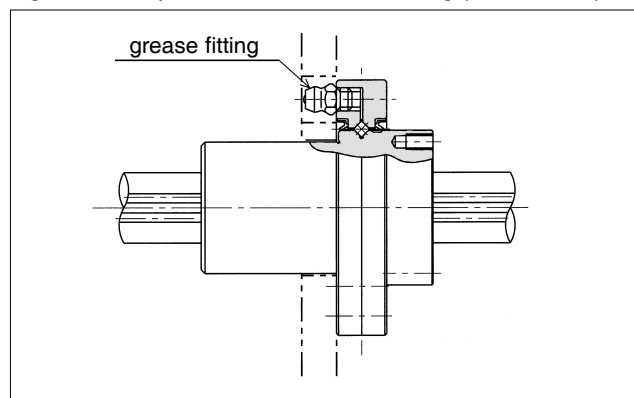

Table 7 Recommended Torque

part number	installation bolt	recommended torque N · m
SPR 6	M2	0.6
SPR 8	M2.5	0.8
SPR10,13	M3	2.0
SPR16,20,25	M4	3.9
SPR30	M6	12.7
SPR40,50,60	M8	29.4

Figure 5 Example of Installed Grease Fitting (SPR 20~60)



# SPR TYPE

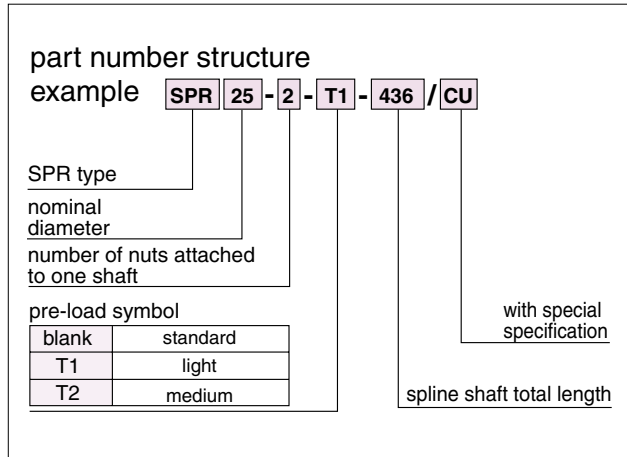

part number	ball spline major dimensions							major dimensions of support bearing									
	D <sub>1</sub>		D <sub>2</sub>		L		P <sub>1</sub>	S	h	l	H	D <sub>3</sub>		P <sub>2</sub>	d	G	θ°
	mm	μm	mm	mm	mm	mm						mm	μm				
<b>SPR 6</b>	20		13	25		16	M2	2.5	5	6.5	30	0/-21	24	2.4	φ2	20°	
<b>SPR 8</b>	22	0	15	25		18	M2.5	3	6	6.5	33	0	27	2.9			
<b>SPR10</b>	27	-21	19	33	0	22	M3	4	8	7	40		-25	33			3.4
<b>SPR13</b>	29		24	36	-0.2	24	M3	5	8	9	50	0	42	3.4	φ3	15°	
<b>SPR16</b>	36	0	31	50		30	M4	6	10	11	60		-30	50			4.5
<b>SPR20</b>	40	-25	34	60		34	M4	7	12	13	66	0	56	4.5	M6×0.75	15°	
<b>SPR25</b>	50		40	70		42	M5	8	13	16	78		-35	68			4.5
<b>SPR30</b>	61	0	47	80		52	M6	10	17	17	100	0	86	6.6			
<b>SPR40</b>	76	-30	62	100	0	64	M6	10	23	20	120	-35	104	9			
<b>SPR50</b>	88	0	75	112	-0.3	77	M8	13	24	22	130	0	114	9			
<b>SPR60</b>	102	-35	90	127		90	M8	13	25	25	150	-40	132	9			

# ROTARY BALL SPLINE

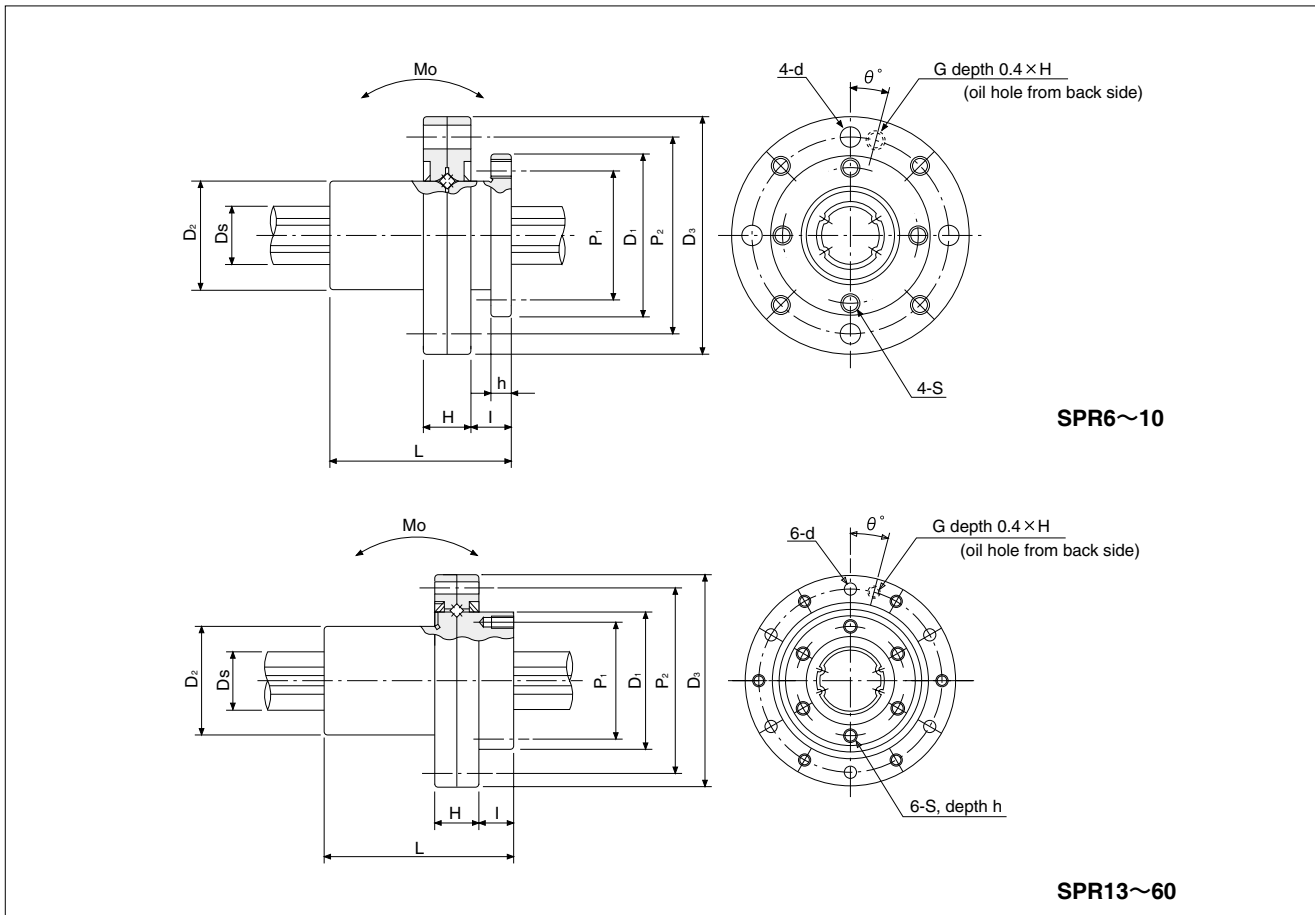

spline shaft		ball spline				support bearing		allowable static moment	second cross-sectional moment of inertia	cross-sectional coefficient	mass		※maximum rotational speed	part number
mm	Ds tolerance	basic torque rating		basic load rating		basic load rating					Mo	kg		
	μm	C <sub>T</sub>	C <sub>OT</sub>	C	C <sub>O</sub>	C <sub>R</sub>	C <sub>OR</sub>	N · m	mm <sup>4</sup>	mm <sup>3</sup>			kg	kg/m
6	0/-12	1.5	2.4	1.22	2.28	0.6	0.5	5.1	59	19.7	0.04	0.21	3,500	<b>SPR 6</b>
8	0	2.1	3.7	1.45	2.87	1.2	1.14	7.4	190	47.6	0.05	0.38	3,500	<b>SPR 8</b>
10	-15	4.4	8.2	2.73	5.07	2.4	2.45	18.0	461	92.2	0.09	0.60	3,000	<b>SPR10</b>
13	0	21	39.2	2.67	4.89	3.0	3.70	13.7	1,380	213	0.17	1.0	1,800	<b>SPR13</b>
16	-18	60	110	6.12	11.2	5.6	6.70	46	2,980	373	0.33	1.5	1,500	<b>SPR16</b>
18.2	0	83	133	7.84	11.3	5.90	7.35	63	5,050	554	0.45	2.0	1,200	<b>SPR20</b>
23		-21	162	239	12.3	16.1	9.11	11.5	104	12,700	1,110	0.75	3.1	1,000
28	-21	289	412	18.6	23.2	13.2	18.0	181	27,500	1,960	1.25	4.8	800	<b>SPR30</b>
37.4	0	637	882	30.8	37.5	22.8	32.3	358	87,300	4,670	2.30	8.6	800	<b>SPR40</b>
47	-25	1,390	3,180	46.1	74.2	27.2	42.1	696	216,000	9,210	3.10	13.1	570	<b>SPR50</b>
56.5	0/-30	2,100	4,800	58.0	127.4	30.0	48.2	1,300	451,000	16,000	4.70	19	500	<b>SPR60</b>

※Maximum rotational speed for grease lubrication.

1kN ≒ 102kgf 1N · m ≒ 0.102kgf · m

Contact NB for further information when higher speeds or oil lubrication is required.

**ISOTECH, inc.**

777 Schwab Road, Suite T, Hatfield, PA 19440  
Toll Free: 800-314-3332 Fax: 215-631-9148